

## Roof walkway for tile roof T350B2

### 1. Instructions for use

- Roof walkways T350B2 are designed and manufactured according to SFS-EN 516, class 2. When installed according to these instructions, the roof walkway can be used as a safety line anchor point (= class 2).
- The safety line is attached around the walkway element between the fixtures, not on the fixtures.
- The safety line may only be used on the same roof plane as the walkway, in the direction of the eaves, and the line must be dimensioned in such a way that the user cannot fall over the eaves.
- An approved safety line (EN 353-2) with fall arrest system and length adjustment must be used. Retractable type fall arresters (EN 360) may be used instead of safety line.
- The roof walkway may only be used as safety line anchor point by one person at a time over a distance of 3 metres. The maximum weight of the person using the anchor point, including equipment, is 100 kg.
- The product may not be used if it is defective or incomplete.

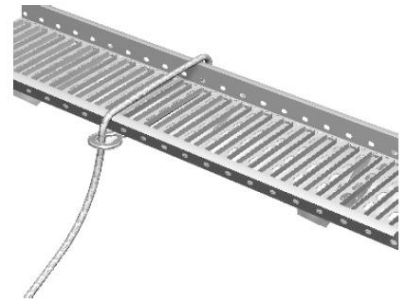

### 2. Planning

- Safe access must be provided for all items on the roof that need maintenance. Roof walkway is used for moving on the roof in the direction of the ridge.
- Roof walkways must be provided for all items on the roof that need maintenance if the slope of the roof is steeper than 1:8 (7°).
- Access to the roof can be arranged from the side or the end of the building. We recommend arranging access to the roof through wall ladders from the end of the building and continuing the access route without interruption as a roof walkway. A prerequisite for this is that the wall ladder and the roof walkway can be placed at the same location.
- If the building has ventilation or sewer lead-throughs, the best location for the roof walkway is usually above them since the roof walkway protects the lead-throughs from any snow sliding on the roof.
- Nesco's vertical safety rail can only be installed on class 2 roof walkways.

### 3. Dimensions and dimensioning of roof walkways

- The roof walkway length is 2.92 m. Consecutive elements overlap 0.12 m, i.e. the effective length is 2.80 m.
- The width of the walking platform is 350 mm and the snow permeability is over 50%.
- The maximum installation distance of the roof walkway fasteners is 1.2 m.

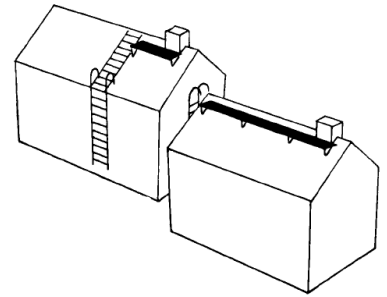

# INSTALLATION

## NESCO

- The products are designed to sustain a point load of 1.5 kN (approximately 150 kg).
- The angle of the fixtures can be adjusted at 11-degree intervals between 0–45°.

### 4. Parts of the roof walkway and package contents

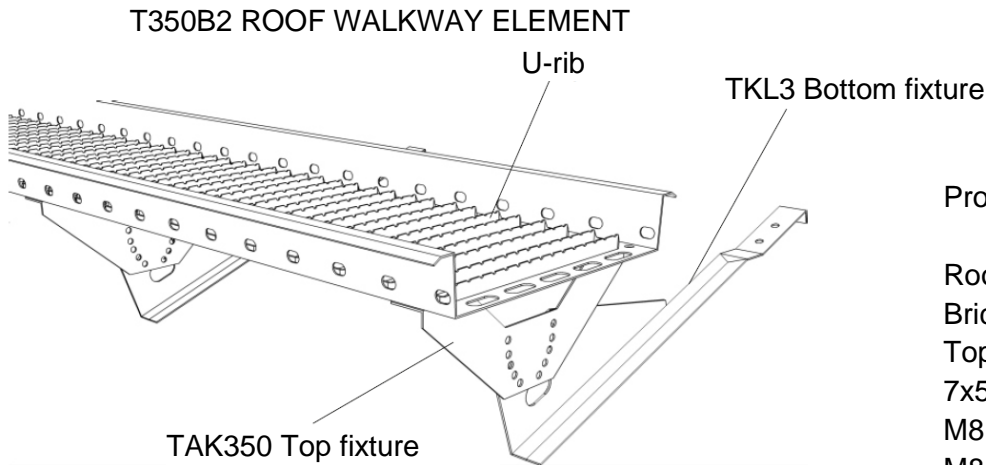

#### Product

Roof walkway T350 2.92 m  
Brick roof fixture TKL3  
Top fixture TAK 350  
7x50 mm HVAC screw  
M8 x 20 mm hexagonal screw  
M8 nut

### 5. Installation order

1. Plan the placement.
2. Plan the fixture intervals. The maximum interval is 1,200 mm.  
The maximum distance of a fixture from the end of the roof walkway is 250 mm.
3. Assemble the fixtures as shown in the figure. The points point in different directions.  
Adjust TAK350 fixture according to the slope of the roof. The fixture has adjustment holes for different slopes, varying from flat roof to 45° slope. The fixtures are assembled on the ground according to the correct slope.

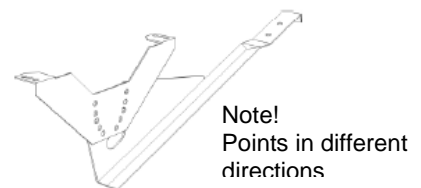

Note!  
Points in different directions

Use two M8 x 20 mm screws and M8 nuts to attach the TAK350 fixture to the roof fixture.

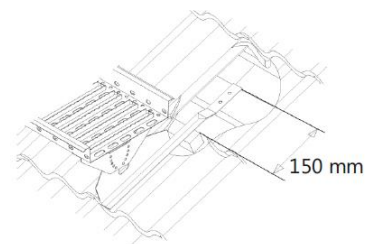

4. Attach the temporary supports.
  - Use strength classified (min. T24) wooden planks, minimum dimensions 50 x 100 mm.
  - Fix the temporary supports as shown in the figure so that the top edge of the support is 150 mm from the top edge of the tile roof's roof batten.

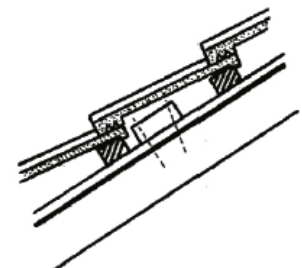

## INSTALLATION

# NESCO

- Use minimum two 6 x 120 mm screws or 6" hot-dip galvanised nails to attach the temporary support through the spacer lath to the roof truss. Place screws to every roof truss so that one of the screws is at an angle as shown in the figure. The screws must be placed at minimum 15 mm from the edge of the temporary support. The temporary battens can be extended by joining them at the roof truss, fixing both ends to the roof truss as described above.

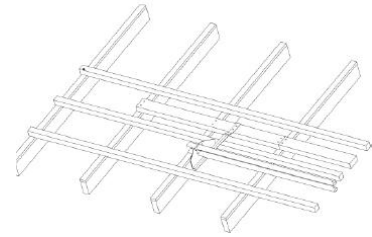

5. Install the fixtures to the temporary support with two 7 x 50 mm HVAC screws in such places that they come to the bottom of the tile grooves.
6. NOTE! This section only applies to AAVA slates. When using AAVA slates, plastic spacer rings KT2 must be placed between the fixture and the temporary support as shown in the figure. In the case of AAVA tiles, the correct fixture location is approximately 75 mm from the edge of the tile so that the fixture is not placed to the seam between the tiles.

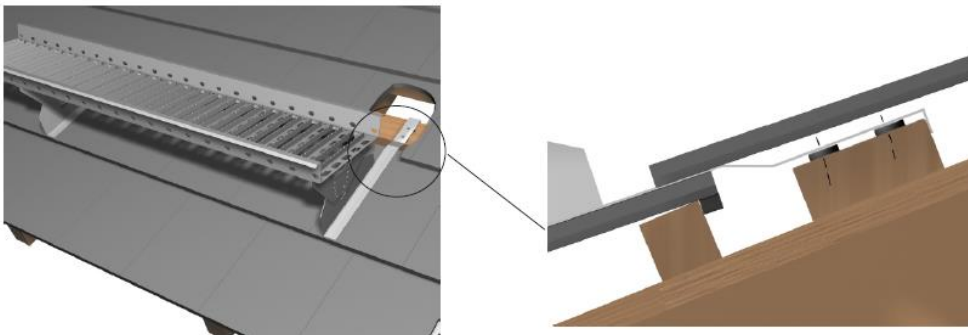

Using spacer rings with AAVA tiles

7. If necessary, use a diamond disc to cut a piece off the tiles where the fixtures will be located so that the tiles fit in properly. The figure shows how to cut the AAVA tiles. Cut off a piece from the bottom of the tile.



8. Lift the roof walkway on the fixtures and use two M8 x 20 mm screws and M8 nuts to attach.

9. Extending the roof walkway.

To extend the roof walkway, overlap the roof walkway elements by 112 mm and attach them to each other using two M8 x 20 mm screws and M8 nuts.

The other end of the roof walkway and the ribs are slightly narrower, allowing the placement of the narrow end into the wide end. Thanks to the sleeves, the roof walkways can be fixed properly to one another with two screws.

You can cut the roof walkway with a hacksaw. The easiest way to do this is to cut at the longest hole location. If you use a hacksaw to cut on the roof, do not leave metal dust on the roofing since it will rust. Use Plaston paint to cover the cut, if necessary.

10. If the roof walkway “sways” sideways, it can be stabilised further by using a roof walkway fixture (KTK) as a diagonal support. The other end is fixed to the hole closest to the ridge in the vertical fixture section with an M8 x 20 mm screw and an M8 nut, and the other end is fixed to the holes at the bottom of the roof walkway with an M8 x 20 mm screw and an M8 nut.

## 6. Maintenance

- In order to keep the installation as a class 2 system, the installation must be inspected once a year by an inspector authorised by the manufacturer.
- The roof walkway is not dimensioned to sustain the snow load of the entire roof and especially not moving masses of snow. Snow must, therefore, be prevented from moving and the stress must be directed at the snow guards.

Nesco Oy Teollisuustie 8 FI-16300 ORIMATTILA 13
EN 516 - 2 - B Roof walkway used for roof maintenance purposes T350B2 DoP: <a href="http://nesco.fi">http://nesco.fi</a>