

Snow guard for bitumen roof

1. Planning the location

- The snow guard is placed where snow falling from the roof forms a hazard or some other reason exists for preventing the snow from falling.
- The snow guard must always cover the entire length of the eaves. It should not be used as short sections (e.g. 3 m) over the entrances only, for example. If this is necessary, however, two rows of snow guards must be used if the length of the roof plane above the snow guard is more than 4 metres (figure 1).
- Snow must always be prevented from falling from one roof plane to another as well (figure 2).
- Place the snow guard close to the side eaves so that the snow loads are transferred to the load-bearing structures.

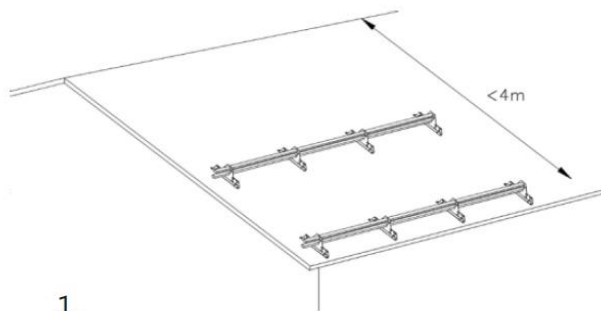

1.

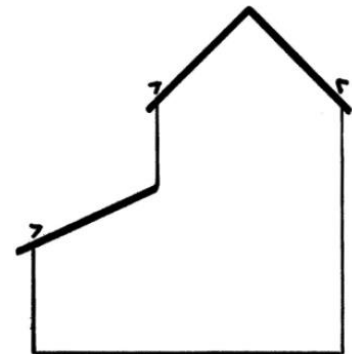

2.

2. Dimensioning of snow guards

Maximum roof plane length above the snow guard (m)						
Angle (°) and slope ratio of the roof	Distance between snow guard fixtures (m)					
Snow load on the roof 1.8 kN/m ² (2.6 kN/m ²)						
	0.5 m	0.6 m	0.75 m	0.9 m	1.0 m	1.2 m
< 15°, (1:3.7)	21.4 (15.0)	17.9 (12.5)	14.3 (9.9)	12.0 (8.3)	10.7 (7.4)	9.0 (6.2)
15...22°, 1:3.7...1:2.5	11.4 (8.0)	9.5 (6.6)	7.6 (5.3)	6.3 (4.4)	5.7 (4.0)	4.8 (3.3)
22...27°, 1:2.5...1:2	8.4 (5.8)	7.0 (4.8)	5.6 (3.9)	4.7 (3.3)	4.2 (2.9)	3.5 (2.4)
27...37°, 1:2...1:1.3	7.4 (5.2)	6.2 (4.3)	4.9 (3.4)	4.1 (2.8)	3.7 (2.6)	3.1 (2.1)
37...45°, 1:1.3...1:1	9.0 (6.2)	7.5 (5.2)	5.9 (4.1)	5.0 (3.5)	4.5 (3.1)	3.7 (2.6)

If this load is exceeded, the snow load on the roof must be reduced.

NOTE! The maximum allowed distance between the fixtures of a snow guard grid is 1,050 mm.

3. Snow guard options

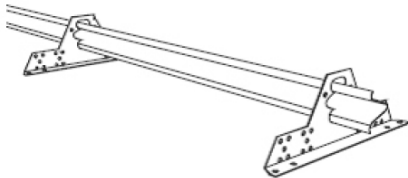

SNOW GUARD WITH PROFILE

- LP3 Snow guard profile 3.0 m
- Roof fixture KL3
- Self-drilling screw 6.3 x 19 mm
- HVAC screw 7 x 50 mm
- Rubber gasket Ø 25 x 5 mm

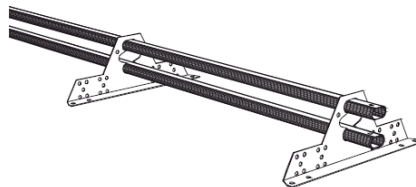

SNOW GUARD WITH 2 OVAL TUBES

- Oval tube 3.0 m
- Roof fixture KL3
- Hexagonal screw M8 x 40 mm
- Nut M8
- HVAC screw 7 x 50 mm
- Rubber gasket Ø 25 x 5 mm

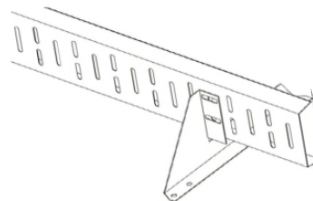

SNOW GUARD WITH GRID

- RLE Snow guard grid 3.0 m
- LER/P Roof fixture
- Hexagonal screw M8 x 20 mm
- Nut M8
- HVAC screw 7 x 50 mm
- Rubber gasket Ø 25 x 5 mm

4. Installation order

1. Plan the placement.
2. Ensure that the boarding under the roofing is made of
 - a) closed boarding with close-grained tongue and groove boards, minimum thickness 23 mm, of good quality.
 - b) Plywood can also be used as the underlay, minimum thickness 15 mm. Using tongue and groove plywood is recommended (e.g. Visa). The products must be attached to plywood by means of through-bolting if the fixtures cannot be placed exactly at the roof trusses.
3. Calculate the fixture distance according to the recommendation of the snow guard table.
4. Mark the locations of the snow guards (using a chalk line, for example) and make sure that the fixtures are in line.
5. Attaching:
 - a) Minimum 23 mm tongue and groove boarding: Attach the fixtures with two 7 x 50 mm HVAC screws at the top and one at the bottom. Seal the lead-throughs with Ø 25 x 5 EPDM rubber gaskets placed between the roofing and the fixture.
 - b) Plywood: Through-bolting with three M8 x 40 mm bolts and minimum Ø 30 x 3 mm metal washers on the underside of the plywood. Place Ø 25 x 5 mm EPDM rubber

gaskets between the roofing and the fixture. If the fixtures can be placed exactly at the roof trusses, follow the instructions of point a).

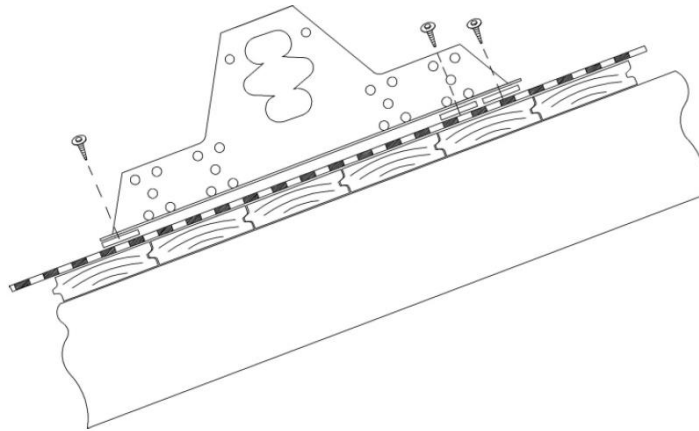

6. Place the snow guard tubes/profile/grid in its place. NOTE! Snow guard profile LP3 must be placed in the fixtures so that point A faces the ridge. The tubes/profile closest to the ends may exceed the last fixture by maximum 100 mm. Use two hexagonal screw M8 x 20 mm to attach snow guard grid RLE to the fixture.
7. Snow guard tubes can be extended by pushing the tapered end into the other tube and locking the connection with an M8 x 30 mm hexagonal screw and an M8 nut. Sideways movement is prevented by placing M8 x 30 mm hexagonal screws and M8 nuts at the ends of the tubes.

Snow guard profile LP3 can be extended by overlapping the profiles by over a distance of minimum 85 mm and locking the connection with four 6.3 x 19 mm self-drilling screws. Sideways movement is prevented by placing 6.3 x 19 mm self-drilling screws at the ends of the profiles.

Snow guard grid RLE can be extended by overlapping the grids over a distance of minimum 85 mm and locking the connection with two M8 x 20 mm hexagonal screws and M8 nuts.