

Roof ladder for corrugated steel roofing and metal multi-tile roofing

1. Instructions for use

- Roof ladders are designed and manufactured according to EN 12951, class 2.
- A roof ladder installed according to these installation instructions may be used as a safety line anchor point (= class 2) if the roof battens are made of close-grained wood, they are in good condition and the size is minimum 28 x 100 mm. The roof ladder may also be attached to 22 x 100 mm roof battens, but in such a case, the roof ladder may not be used as a safety line anchor point.
- We recommend attaching the safety line around the side rails, but it can also be attached to the rungs.
- NOTE! The safety line may not be attached to the fixtures or the plastic feet.
- The safety line may only be used on the same roof plane as the ladder, in the direction of the eaves, and the line must be dimensioned in such a way that the user cannot fall over the eaves.
- An approved safety line (EN 353-2) with fall arrest system and length adjustment must be used. Retractable type fall arresters (EN 360) may be used instead of safety line.
- A roof ladder may only be used as safety line anchor point by one person at a time. The maximum weight of the person using the anchor point, including equipment, is 100 kg.

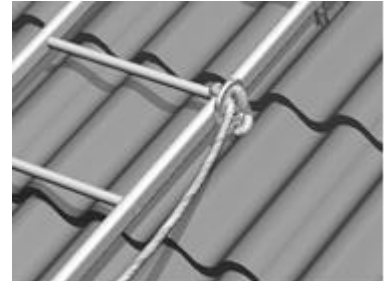

2. Planning

- Safe access must be provided for all items on the roof that need regular maintenance or inspections if the slope of the roof is steeper than 1:8 (7°).
- Using a separate snow guard at the roof ladder location is recommended. The roof ladder is not a snow guard.
- Plan the placement of the roof ladder and the wall ladder so that they are at the same place.
- Nesco's vertical safety rail can only be installed on class 2 roof ladders.

3. Dimensions and dimensioning of roof ladders

- The distance of the bottom rung of the roof ladder from the top rung of the wall ladder may not exceed 400 mm (Nat. Building Code F2).
- The rung distance is 300 mm and the internal distance of the side rails is 400 mm.
- The products are designed to sustain a point load of 1.5 kN (approximately 150 kg).

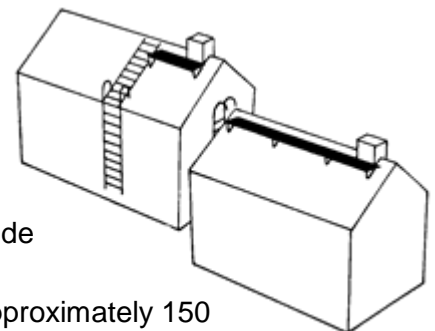

4. Parts of the roof ladder and package contents

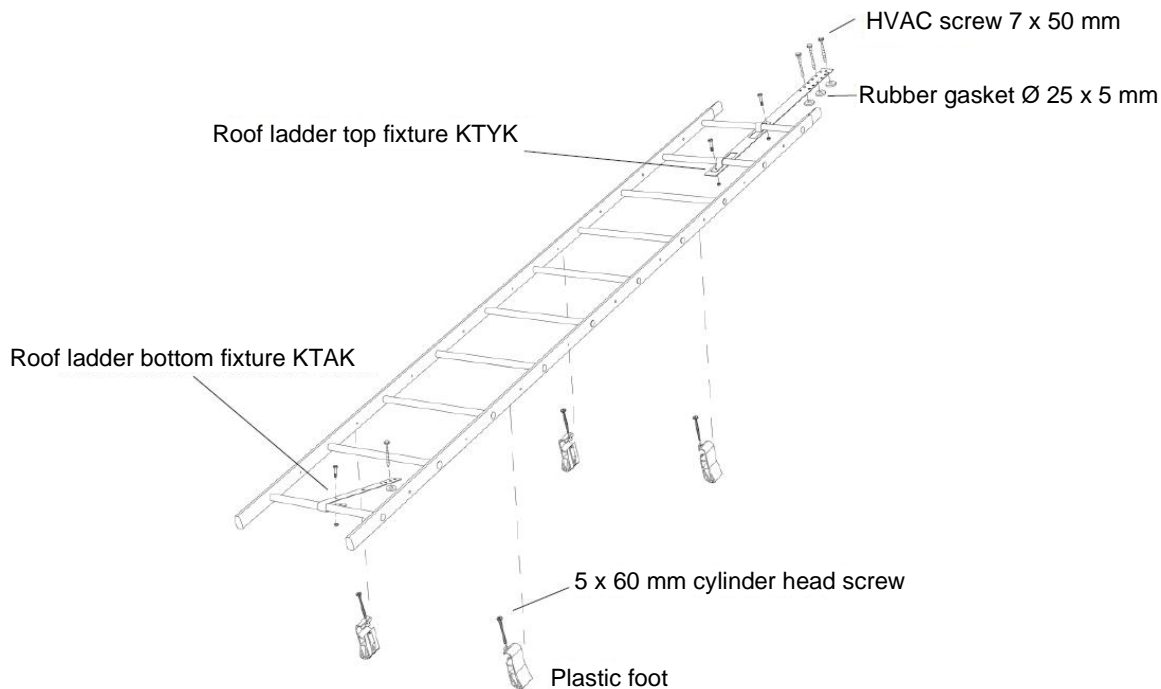

5. Installation order

1. Extend the standard ladder to the correct length on the ground using M8 x 40 mm hexagonal screws and cut of any excess using a hacksaw.
2. Place the plastic ladder feet in the side rails of the ladder at approximately 1.5–2.0 m intervals. The plastic feet are asymmetric, so try which is the best position for the roofing in question. Place the cylinder head tightening screws (5 x 60 mm) of the plastic feet in their places but do not tighten them yet.

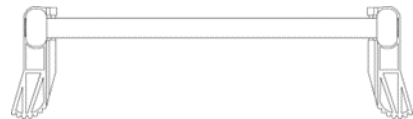
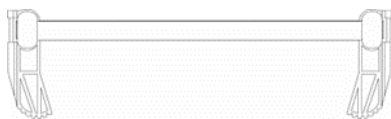

3. Attach the roof ladder top fixture to the two rungs at the top by passing the top fixture in its place and tightening the fixture handles around the rungs using an M8 x 20 mm hexagonal screw and an M8 nut.

4. Lift the ladder in its place and attach it using the roof ladder top fixture
 - a) Under the ridge capping:
Attach with 7 x 50 mm HVAC screws to battens under the ridge capping.
Note that the attachment screws may not be placed closer than 15 mm from the edge of the roof batten.
 - b) On the roof plane:
Use three 7 x 50 mm HVAC screw to attach where it is certain that there is a roof batten,
a roof truss or other wooden part comparable to the frame structures. Use Ø 25 x 5 mm EPDM rubber gaskets for sealing the screw lead-throughs. Note that the attachment screws may not be placed closer than 15 mm from the edge of the roof batten.

Attach the roof ladder bottom fixture (KTAK) at the bottom of the ladder to the roof batten with one 7 x 50 mm HVAC screw. Use Ø 25 x 5 mm EPDM rubber gaskets for sealing the lead-through. Tighten the cylinder head screws of the plastic feet.

5. If a wall ladder is attached on the building at the same place, attach the top curves of the wall ladder to the roof ladder using the U flanges. Tighten with M8 x 40 mm hexagonal screws and M8 nuts.

6. Maintenance

- In order to keep the installation as a class 2 system, the installation must be inspected once a year by an inspector authorised by the manufacturer.
- The roof ladder is not dimensioned to sustain the snow load of the entire roof and especially not moving masses of snow. Snow must therefore be prevented from moving and the stress must be directed at the snow guards. If no snow guards have been installed, the snow must be cut regularly on both sides of the roof ladder to reduce loads.



Nesco Oy Teollisuustie 8 FI-16300 ORIMATTILA 13
EN 12951 Fixed roof ladders C2-TB DoP: http://nescos.fi