

Snow guard for standing seam roof

1. Planning the location

- The snow guard is placed where snow falling from the roof forms a hazard or some other reason exists for preventing the snow from falling.
- The snow guard must always cover the entire length of the eaves. It should not be used as short sections (e.g. 3 m) over the entrances only, for example. If this is necessary, however, two rows of snow guards must be used if the length of the roof plane above the snow guard is more than 4 metres (figure 1).
- Snow must always be prevented from falling from one roof plane to another as well (figure 2).
- Place the snow guard close to the side eaves so that the snow loads are transferred to the load-bearing structures.

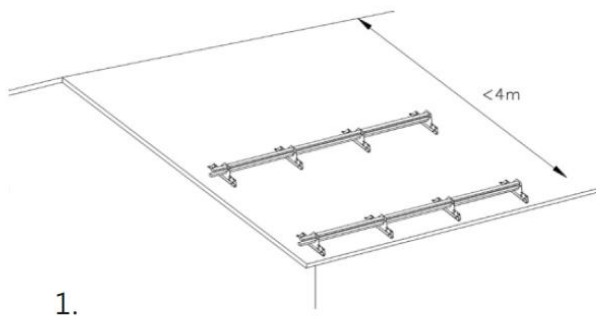

1.

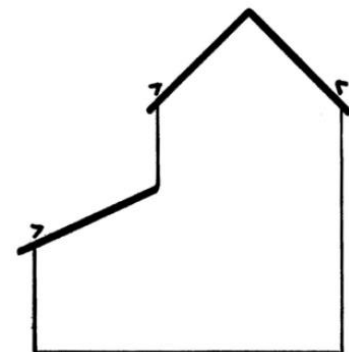

2.

2. Dimensioning of snow guards

Maximum roof plane length above the snow guard (m)						
Angle (°) and slope ratio of the roof	Distance between snow guard fixtures (m)					
Snow load on the roof 1.8 kN/m ² (2.6 kN/m ²)						
	0.5 m	0.6 m	0.75 m	0.9 m	1.0 m	1.2 m
< 15°, (1:3.7)	21.4 (15.0)	17.9 (12.5)	14.3 (9.9)	12.0 (8.3)	10.7 (7.4)	9.0 (6.2)
15...22°, 1:3.7...1:2.5	11.4 (8.0)	9.5 (6.6)	7.6 (5.3)	6.3 (4.4)	5.7 (4.0)	4.8 (3.3)
22...27°, 1:2.5...1:2	8.4 (5.8)	7.0 (4.8)	5.6 (3.9)	4.7 (3.3)	4.2 (2.9)	3.5 (2.4)
27...37°, 1:2...1:1.3	7.4 (5.2)	6.2 (4.3)	4.9 (3.4)	4.1 (2.8)	3.7 (2.6)	3.1 (2.1)
37...45°, 1:1.3...1:1	9.0 (6.2)	7.5 (5.2)	5.9 (4.1)	5.0 (3.5)	4.5 (3.1)	3.7 (2.6)

If this load is exceeded, the snow load on the roof must be reduced.

3. Snow guard and package contents

Snow guard tubes

- Snow guard tube, oval, 3.0 m
- Roof fixture KL3
- SK Counter piece
- Hexagonal screw M8 x 30 mm
- Nut M8

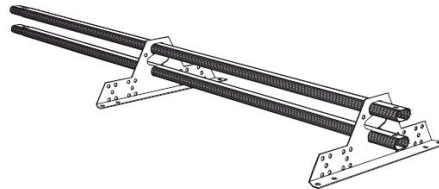

Snow guard with profile

- LP3 Snow guard profile 3.0 m
- Roof fixture KL3
- SK Counter piece
- Self-drilling screw 6.3 x 19 m
- Hexagonal screw M8 x 30 mm
- Nut M8

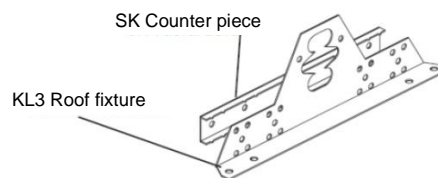

4. Installation order

1. Plan the placement.
2. Ensure that the boarding under the snow guard is made of closed boarding as required by the RT instruction card. Check also that the number of fixture strips used for attaching the metal sheeting is adequate (RT instruction card 85-10862, standing seam metal roof).
3. Calculate the fixture distance according to the recommendation of the snow guard table. The most commonly used distribution is 1.04 m and the maximum distance is 1.2 m.
4. Mark the locations of the snow guards (using a chalk line, for example) and make sure that the fixtures are in line.
5. Attach the fixtures one by one. Always place the larger fixture (KL3) on the straight side of the seam so that the fixture stands vertical. Correspondingly, the U-shaped counter piece (SK) is placed on the overturned seam side.
6. Tighten the counter piece with four M8 x 30 mm hexagonal screws and M8 nuts. The tightness of the bolts is correct when the counter piece begins to bend at the bolt locations. Additional tightening does not help after this.
7. Place the snow guard tubes/profile in their places. In the profile, point A faces the ridge. The tubes/profiles closest to the ends may exceed the last fixture by a maximum of 100 mm.

INSTALLATION

NESCO

8. Snow guard tubes can be extended by pushing the tapered end into the other tube and locking the connection with an M8 x 30 mm hexagonal screw and an M8 nut. Sideways movement is prevented by placing M8 x 30 mm hexagonal screws and M8 nuts at the ends of the tubes.

Snow guard profile LP3 can be extended by overlapping the profiles by over a distance of minimum 85 mm and locking the connection with four 6.3 x 19 mm self-drilling screws. Sideways movement is prevented by placing 6.3 x 19 mm self-drilling screws at the ends of the profiles.